



# ECO SCROLL

OIL-FREE AIR COMPRESSORS

4 - 15 kW

8 - 10 bar





# FS-CURTIS®

# ECO SCROLL OIL-FREE AIR COMPRESSORS



The FS-Curtis ECO Scroll Series comprises a range of oil-free air compressors offering superior energy efficiency, ease of operation, quietness and compactness in an environmentally responsible manner.

The four models in the ECO Scroll Series from 4 to 15 kW perfectly fill the niche between reciprocating compressors and rotary screw compressors for oil-free compressed air supply. They are ideal for applications where stringent cleanliness is critical, such as dental and medical facilities, food and beverage processing, chemical and pharmaceutical manufacturing, and water treatment.

## FEATURES AND BENEFITS

### Oil-Free Compressed Air

- 100% oil-free compressed air output.
- ISO 8573-1 Class 0 air quality of the highest standard.
- 100% oil-free condensate water discharge.

### Powerful Compressor Air-End

- Unique second-generation scroll compressor air-end design.
- Class-leading free air delivery and specific energy efficiency.
- 100% duty cycle capability at 8 or 10 bar rated pressure.

### Energy Efficient Motor and Controls

- IE3 premium efficiency, IP54 Class F electric drive motor.
- Automatic start/stop control eliminates wasteful no-load running.

### Ultra Quiet Running

- Extremely low operating noise and vibration emissions.
- 57 to 63 dB(A) noise level at rated output, depending on model.
- No noise hazard from 24/7 use in the workplace.

### Innovative Compact Design

- Small cabinet footprint occupies minimal floorspace.
- Fits through a standard doorway for ease of installation.

### Low Maintenance Requirements

- Quick and easy minor service tasks at 2,500-hour<sup>#</sup> intervals.
- 10,000-hour<sup>#</sup> major service includes tip seal replacement.

### Proven Reliability in Use

- Minimum number of moving parts ensures inherent reliability.
- No metal-to-metal contact between the compressor scrolls.
- Experience from thousands of units in-service worldwide.

### Optimal Compressor Management

- Advanced multi-function electronic controller.
- Automatic monitoring and control of all functions.

### Cool and Dry Compressed Air

- Integral air-end cooling fan and electric fan-forced aftercooler.
- Electronic timer valve drains out accumulated condensate.

### Peace of Mind Confidence

- Comprehensive 24-month warranty (conditions apply).
- FS-Curtis is a member of the global Fusheng Group, one of the world's largest manufacturers of air compressors with a history of excellence spanning over 165 years.

<sup>#</sup> Dependent on ambient temperature.

## ADVANCED SCROLL COMPRESSOR TECHNOLOGY

The scroll compressor air-end features one scroll moving in an eccentric orbital motion relative to an inter-meshed fixed scroll. Compression is achieved by the intake air being squeezed into a continuously decreasing volume as it progresses through the air-end. This process is virtually constant and pulsation-free with negligible noise and vibration.

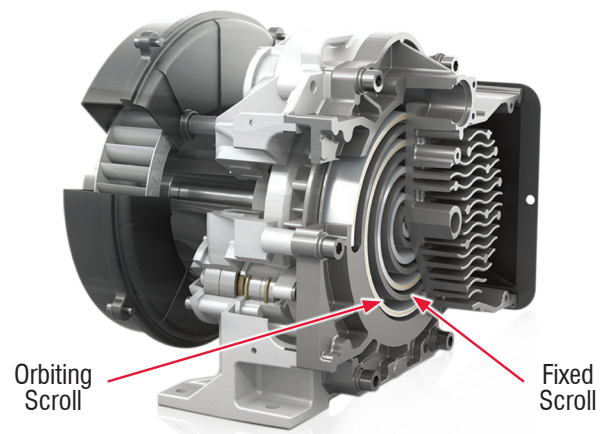

Scroll Compressor Air-End (cutaway view)

## MODULAR DESIGN CONCEPT

FS-Curtis ECO Scroll compressors are fitted with a proprietary air-end that has been computer designed and precision manufactured in-house by Fusheng.

The ES04 model is fitted with a single motor and air-end module while the larger ES08, ES11 and ES15 models have up to four modules.

This design concept offers lower cost and higher reliability due to mass production of the standardized motor and air-end module.



ES15 (access panels and guards removed)

# INTELLIGENT MONITORING AND CONTROL



**ES04 Controller**



**ES08-15 Controller**

All models in the FS-Curtis ECO Scroll Series are fitted with an intelligent controller for precise management of the compressor's operation and maintenance via an intuitive user-friendly interface. Both the ES04 and ES08-15 controllers are supplied as standard with a fully-loaded array of comprehensive functions, including:

- 4-inch LCD high-contrast, non-touch screen display (ES04).
- 7-inch LCD full-colour, touch-screen display (ES08-15).
- Easy-to-read home screen multi-parameter display including system pressure and individual compressor module status.
- Automatic start/stop control of multiple compressor modules including fail-safe running of operable modules.
- Sequential control of up to four interconnected compressor sets including fail-safe running of operable sets.
- Automatic variation of dispatch to evenly share runtime across multiple compressor modules or sets.
- Three programmable daily on/off timers with individual pressure settings (ES08-15 only).
- Selectable automatic restart after blackout.
- Remote on/off control of standalone compressor sets.
- Modbus RS-485 data communication that integrates with building and industrial automation systems.
- Maintenance timer and scheduler for each major component.
- Main motor, fan motor and drain valve test functions (ES08-15 only).
- Abnormal operation and overdue maintenance warnings.
- Automatic operating fault shutdown protection.
- Warning and fault logs for ease of troubleshooting.
- Multi-level security password protection.

## TECHNICAL DATA

Model #	Free Air Delivery @ 8 bar (116 psi)		Free Air Delivery @ 10 bar (145 psi)		Motor Power		Noise Level	Air Outlet	Width	Depth	Height	Weight
	m <sup>3</sup> /min *	cfm *	m <sup>3</sup> /min *	cfm *	kW	hp	dB(A) <sup>Δ</sup>	inch	mm	mm	mm	kg
ES04	0.43	15.0	0.35	12.2	3.7	5	57	1/2	640	604	895	170
ES08	0.85	30.0	0.69	24.4	7.5	10	59	3/4	1,020	750	1,645	440
ES11	1.28	45.0	1.04	36.6	11	15	61	1	1,600	750	1,830	685
ES15	1.70	60.0	1.38	48.8	15	20	63	1	1,600	750	1,830	770

\* According to ISO 1217 Annex C. Δ According to ISO 2151 with an uncertainty of 3 dB(A) # Add suffix -08B or -10B to designate pressure.





# ECO SCROLL

OIL-FREE AIR COMPRESSORS

MADE IN TAIWAN

Authorised FS-Curtis Dealer

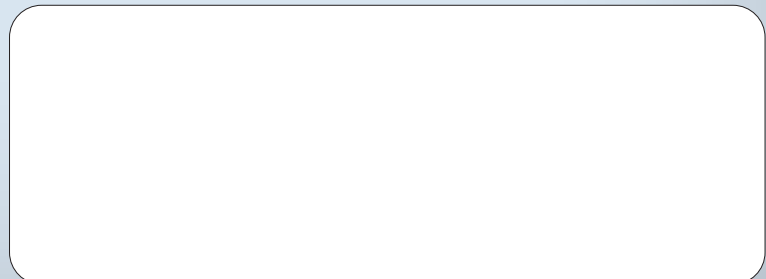

 **FSCURTIS**<sup>®</sup>  
FSCURTIS.COM.AU